



EMB S.r.l

Via degli artigiani,8
26014 - Romanengo (CR)

CODICE/CODE	711427
TIPO/TYPE:	BBT3004924DCTH39
MOTORE N.°/MOTOR N.	14-57

DESCRIZIONE/DESCRIPTION:

- Doppio stadio/Two stage
- **24V. DC**
- Classe di isolamento I /Insulating class I
- Classe di temperatura F /Temperature class F
- 2 cuscinetti/Double ball bearings
- 1 velocità/ Single speed
- By Pass scarico tangenziale/Tangential bypass discharge
- Basamento termoplastico/Thermoplastic base fan motor
- Ponticello Alluminio/Aluminium bridge commutator side

Test Date:	11-lug-14
Hours:	16:45
Room Temp:	26,4°c.
RH:	53%
Absolute Bar Press.:	1008 mbar

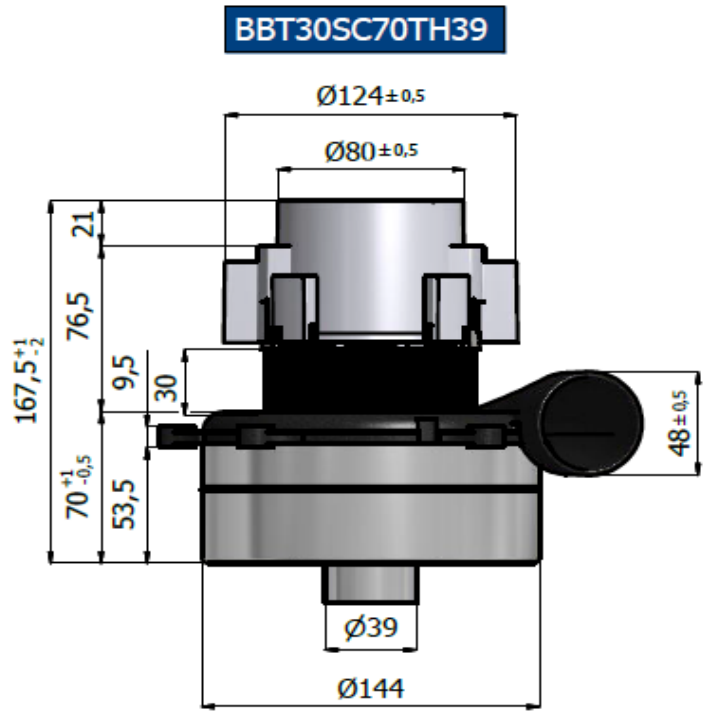

**CARATTERISTICA DI ASPIRAZIONE CON MOTORE APPLICATO SU CASSA DI MISURA
TYPICAL MOTOR PERFORMANCE ON MEASURING BOX**

Orifice mm	Current A	Input pow. W	Speed RPM	Vacuum/Depressure		Air Flow L/sec	Air Watts W	Efficiency %	Sound Level dB-max	Test Voltage :
				mm H2O	mbars					24
48	20,40	490	14.730	52	5,10	31	16	3,2	84,4	Frequency :
40	20,60	494	14.720	109	10,7	32	34	6,9	81,5	Nominal Power W. 500
30	20,70	497	14.650	298	29,2	30	88	17,6	78,1	Middle Power W. 425
23	20,60	494	14.660	568	55,7	24	134	27,0	75,7	Max. Power W. 584
19	20,10	482	14.910	730	71,6	19	133	27,5	74,8	Vacuum mmH2O 1418
16	19,30	463	15.260	855	83,8	14	120	25,9	75,8	Air Flow L/s. 32
13	18,30	439	15.860	986	96,7	10	97	22,1	77,2	Air Power W. 134
10	17,10	410	16.530	1098	107,6	6	70	17,0	78,3	Efficiency % 27,5
6,5	16,20	389	17.340	1226	120,2	3	31	7,9	82,3	
0	15,00	360	18.070	1418	139,0	0	0	0,0	82,1	

