

**EMB S.r.l**Via degli artigiani,8
26014 - Romanengo (CR)

TIPO/TYPE:	BBT300682302TH39
MOTORE N.°/MOTOR N.:	14-16
Codice/code	711354
Serie:	Standard

DESCRIZIONE/DESCRIPTION:

- Doppio stadio/Two stage
- 230V. 50/60Hz.
- Classe di isolamento II /Insulating class II
- Classe di temperatura F /Temperature class F
- 2 cuscinetti/Double ball bearings
- 1 velocità/ Single speed
- By Pass scarico tangenziale/Tangential bypass discharge
- Basamento termoplastico
- Ponticello termoplastico

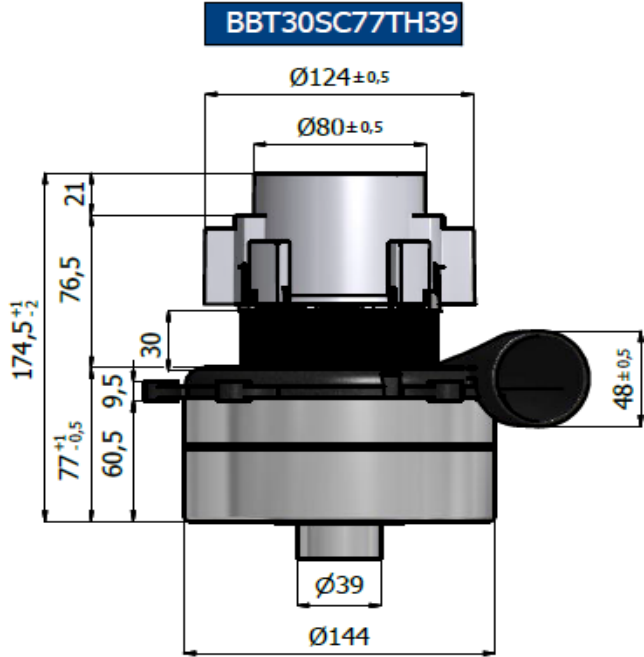

Test Date:	10/02/2016
Hours:	15:00
Room Temp:	25,6°C
RH:	10,2%
Absolute Bar Press.:	999

**CARATTERISTICA DI ASPIRAZIONE CON MOTORE APPLICATO SU CASSA DI MISURA
TYPICAL MOTOR PERFORMANCE ON MEASURING BOX**

Orifice mm	Current A	Input pow. W	Speed RPM	Vacuum/Depressure		Air Flow L/sec	Air Watts W	Efficiency %	Sound Level dB Max	Test Voltage : 230	
				mm H2O	mbars					Frequency :	50Hz.
48	3,19	688	15.660	72	7,1	38	27	3,9	79,8		
40	3,19	688	15.590	150	14,7	38	55	8,0	80,1	Nominal Power W.	689
30	3,23	692	15.540	407	39,9	35	140	20,3	78,6	Middle Power W.	586
23	3,16	684	15.780	743	72,8	27	199	29,2	78,0	Max. Power W.	814
19	3,03	652	16.070	930	91,2	21	191	29,3	75,6	Vacuum mmH2O	1618
16	2,86	624	16.560	1077	105,6	16	170	27,2	76,3	Air Flow L/s.	38
13	2,68	584	17.420	1216	119,2	11	133	22,7	76,4	Air Power W.	199
10	2,49	548	17.900	1334	130,8	7	94	17,1	78,0	Efficiency %	29,3
6,5	2,34	508	18.640	1462	143,3	3	40	7,9	77,3		
0	2,16	480	19.390	1618	158,6	0	0	0,0	81,4		

